

Service Manual, in many cases in actual use. Refer to the Special Service Tool Catalog for a description and ordering instructions for these tools.

OUTBOARD MOTOR NOMENCLATURE

Sometimes the words "right" and "left" are very confusing when referring to the sides of an outboard motor. Therefore, the sides are referred to as STARBOARD or PORT sides. STARBOARD means on the right hand while facing the bow (FRONT) of the boat; PORT means left hand. See Figures 1-1 and 1-2.

Service required for the 2 HP motor is generally one of three kinds . . .

1. **NORMAL CARE AND MAINTENANCE**, which includes putting a new motor into operation, storing motors, lubrication, and care under special operating conditions such as salt water and cold weather.
2. **OPERATING MALFUNCTIONS** due to improper motor mounting, propeller condition or size, boat condition, or the malfunction of some part of the motor. This includes motor tune-up procedures to keep the motor in prime operating condition.
3. **COMPLETE DISASSEMBLY** and overhaul, such as inspecting a motor that has been submerged, or rebuilding trade-in units.

It is important to you as the service man to determine before disassembly just what the trouble is, and how to correct it quickly and with minimum expense to the owner. Refer to the Trouble Check chart in Section 2 to help you diagnose motor malfunctions.

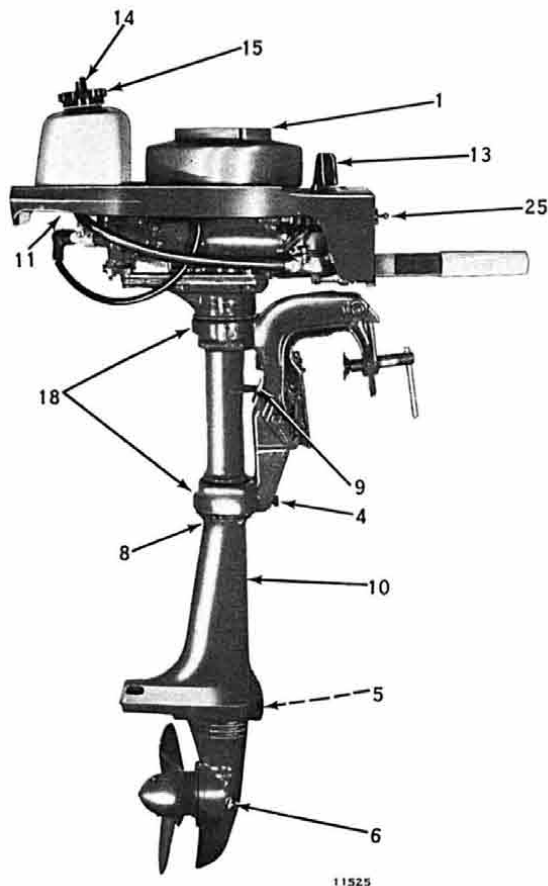

Figure 1-1. Starboard View Less M/C

1. Starter rope pulley
2. Steering handle
3. High speed knob
4. Steering friction screw
5. Water pump
6. Oil drain and fill plug
7. Exhaust outlet
8. Exhaust relief and water outlet
9. Reverse lock
10. Exhaust housing
11. Fuel valve
12. Motor rest
13. Speed control
14. Fuel vent
15. Filler cap
16. Model and serial number plug
17. Swivel bracket
18. Pivot brg. retainers
19. Propeller
20. Skeg
21. Water intake
22. Tilt rod
23. Clamp screw
24. Model and serial number plate
25. Choke
26. Low speed needle
27. Rewind Starter

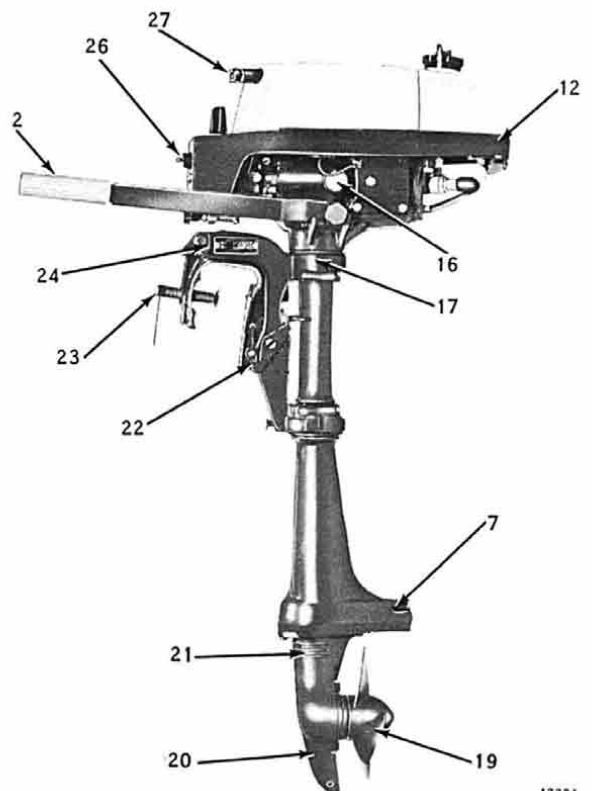

Figure 1-2. Port Side View Less M/C